

# MUSEUM on Main Street

## Water/Ways Size Requirements

Your Museum on Main Street exhibition will arrive with everything needed to install it in your space. A few preparations will make your installation run smoothly and will better safeguard the exhibition while it is in your care.

### Program Workshop

A program workshop will be held approximately six to nine months before the exhibition opens at the first venue on your state's tour. It is a required part of your participation in Museum on Main Street and it is recommended that at least two people from each community attend the workshop, preferably the local coordinator and an assistant coordinator. The workshop is organized by your state humanities council and a Smithsonian representative will lead a discussion on the content of the exhibition. At the workshop you will meet the coordinators from all of the other host sites in your state as well as the state scholar and other statewide partners. You will learn about the content of the exhibition; brainstorm local program and exhibition ideas; discuss publicity, fundraising, and grants from your state humanities council; and discover other resources that will help you successfully host the MoMS exhibition in your town.

### Installation Workshop

An installation workshop will be held before the opening at the first venue on your state's tour. It is a required part of your participation in Museum on Main Street and it is recommended that at least two people from each community attend the workshop, preferably the local coordinator and the person responsible for the installation and de-installation of the exhibition. The workshop is organized by your state humanities council and the installation is led by a representative from the Smithsonian Institution. At the workshop you will learn how to completely install the exhibition, how to take care of the exhibition, and what to do if something goes wrong. An installation manual is included in this manual but it cannot replace the experience of putting the exhibition together under the guidance of a MoMS staff person familiar with the exhibition.

### Space Planning

Each Museum on Main Street exhibition consists of 5 – 8 free-standing kiosks and takes up 600 – 850 square feet depending on the exhibition (see below for information on each exhibition). If you plan to supplement the exhibition with local objects or exhibitions you will require more gallery space. However, wall hangings can be displayed within this space requirement. Please refer to the Exhibition Layout document in the Exhibition Specifics section of this manual for specific kiosk dimensions and recommended layouts.

*The Way We Worked* – 600 square feet, 8' 6" ceiling height minimum

*Hometown Teams* – 850 square feet, 8' 6" ceiling height minimum

*Water/Ways* – 650 square feet, 8' 6" ceiling height minimum

Marking out the kiosks on the floor with tape prior to assembling or using the included exhibition layout sticks will make your installation easier and will prevent you from having to disassemble and move components of the exhibition if something doesn't fit. It is recommended that you leave at least 36 inches between kiosks and walls to comply with ADA requirements. Also, if you

were thinking of putting the exhibition on an upper floor, make sure that it is ADA accessible and you can get the crates upstairs.

If you have questions about your space or would like help planning your layout please contact your assigned Smithsonian representative. Those assignments and their contact information can be found on the Key Contacts list in the Exhibition Specifics section of this manual.

Your gallery space does not need to be climate-controlled, but does need to be clean, cool (below 75 degrees F) and dry, especially dry. Excessive humidity, above 65%, can damage some of the graphics. Direct sunlight can fade the panels. You should use blinds or other light blockers to limit direct sunlight. Incandescent or halogen lighting is best and only during opening hours.

### **Installation**

All of the tools you will need to install the exhibition come packed in the crates. It is a good idea to have a step-stool handy. Follow the installation instructions you received at the installation workshop or that are included in the last section of this manual. You will need at least four people to install the exhibition but we recommend you have no more than 6 people. You or someone else who participated in the installation workshop must be present and guide the installation in your venue. One person should be in charge of reading the directions and directing everybody else. The others should get the panels and connectors out the crates and put them in place. At least one person should be assigned to hold panels as they go up, particularly on the top level, to prevent them from falling before the connectors are in place. The entire installation will take about 3 – 6 hours. Plan an entire day to allow for breaks.

### **De-Installation**

You will take the exhibition down in the reverse order that you put it up. There are de-installation instructions on the MoMS website, [www.museumonmainstreet.org](http://www.museumonmainstreet.org). Please take your time while taking down the exhibition. **Most damage to exhibitions occurs during the de-installation!** Again, make sure that whoever attended the installation workshop is present and overseeing the de-installation. Go slowly and make sure that everything is packed in its proper place in the crates. Double-check all the connector trays to make sure that there aren't any broken or lost connectors.

### **Crates and Shipping**

Each MoMS exhibition contains 12 – 21 crates. The crates are all on wheels and roll easily and they are all designed to fit through a single doorway. When packed, the crates weigh between 150 and 300 pounds. If you need to move the crates upstairs, they can either be lifted with a few strong men or you can unpack them and move the components up the stairs individually.

You will need to store the crates while the exhibition is installed. Storage can be either on-site or off. The chosen space must be approximately 300 square feet, and be cool, dry, and clean. Crates may be stacked once they are empty. When empty, the crates weigh about 50 pounds.

Shipping arrangements are generally made by your state humanities council coordinator but this sometimes includes requiring you to pick up or deliver the exhibition to another venue. If you are asked to ship the exhibition please follow these recommendations and requirements.

The exhibition must be packed in an enclosed truck. No open pickup trucks, please! Most MoMS exhibitions will fit in a 26' U-Haul truck. The crates must travel upright on their wheels. Ropes or parachute cord should be used to prevent the crates from rolling or sliding around in

the truck. One person should stay with the truck at all times and it should be locked during transport. A lift gate is necessary for loading and unloading.

If a professional shipping company is moving the exhibition plan to have a few strong people greet the shipper so that the crates can be brought into the gallery. You can request an inside delivery by the driver but that often costs more. Please make sure that the crates are tied into the truck before it leaves your venue regardless of who is making the shipping arrangements.

Shipments to the first venue and from the last venue in the state are arranged and paid for by the Smithsonian. If you have questions about these shipments, please contact Terri Cobb at the Smithsonian, 202-633-5334 or [cobbt@si.edu](mailto:cobbt@si.edu).

# Water/Ways Sections 1 and 5

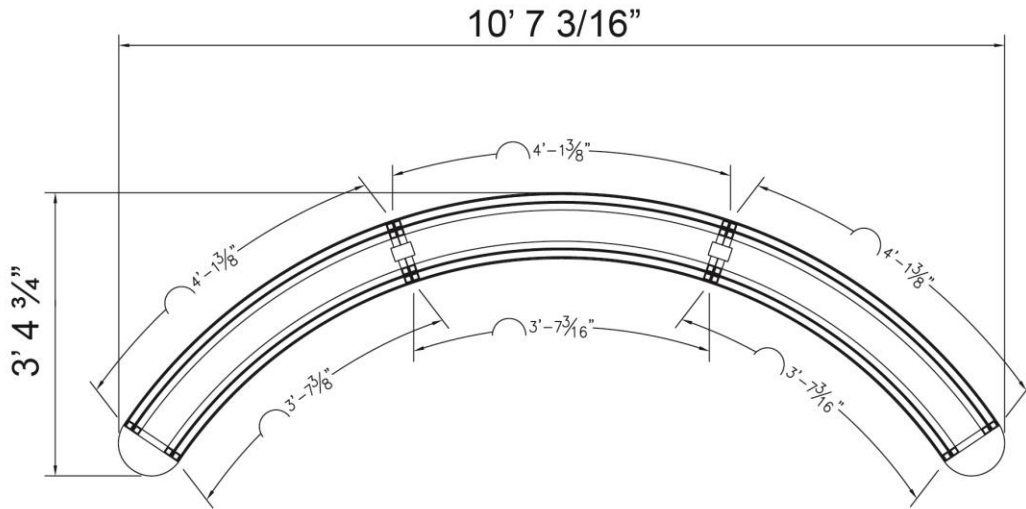

# Water/Ways Sections 2 and 4

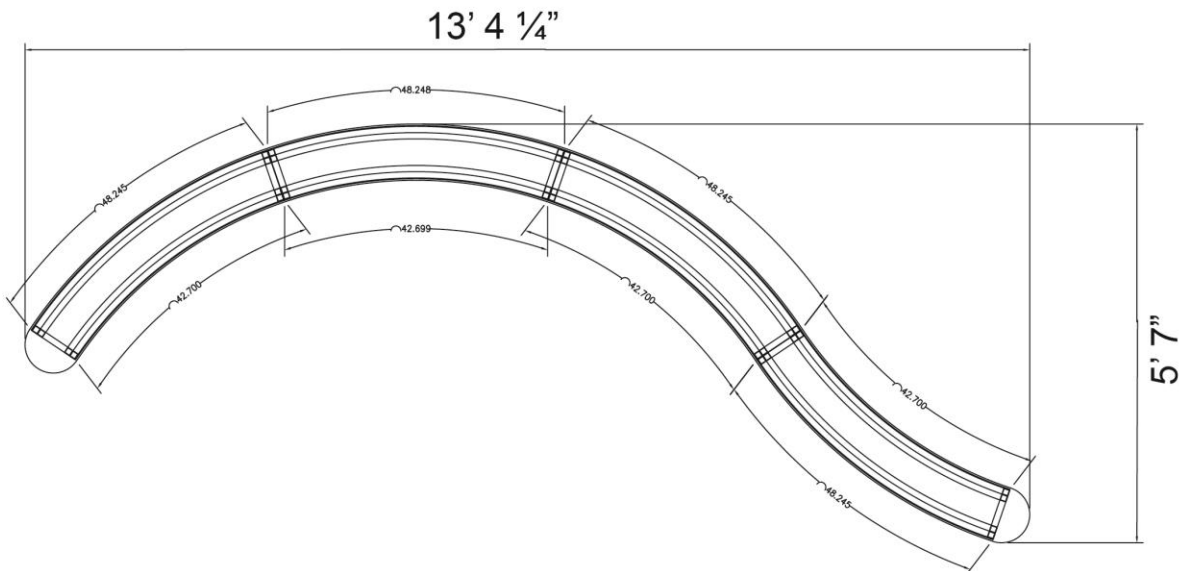

# Water/Ways

## Section 3: Flow

